

Detail of End Plates  
Note: Scale 1:1

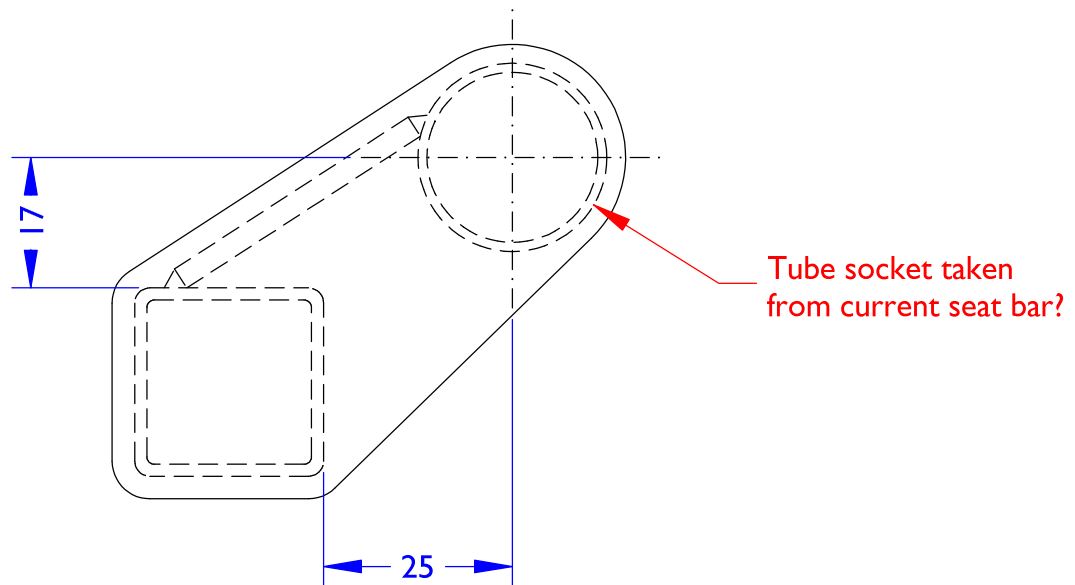

**COMFORTMAX**  
Seat Bar  
1:2 (Detail 1:1)

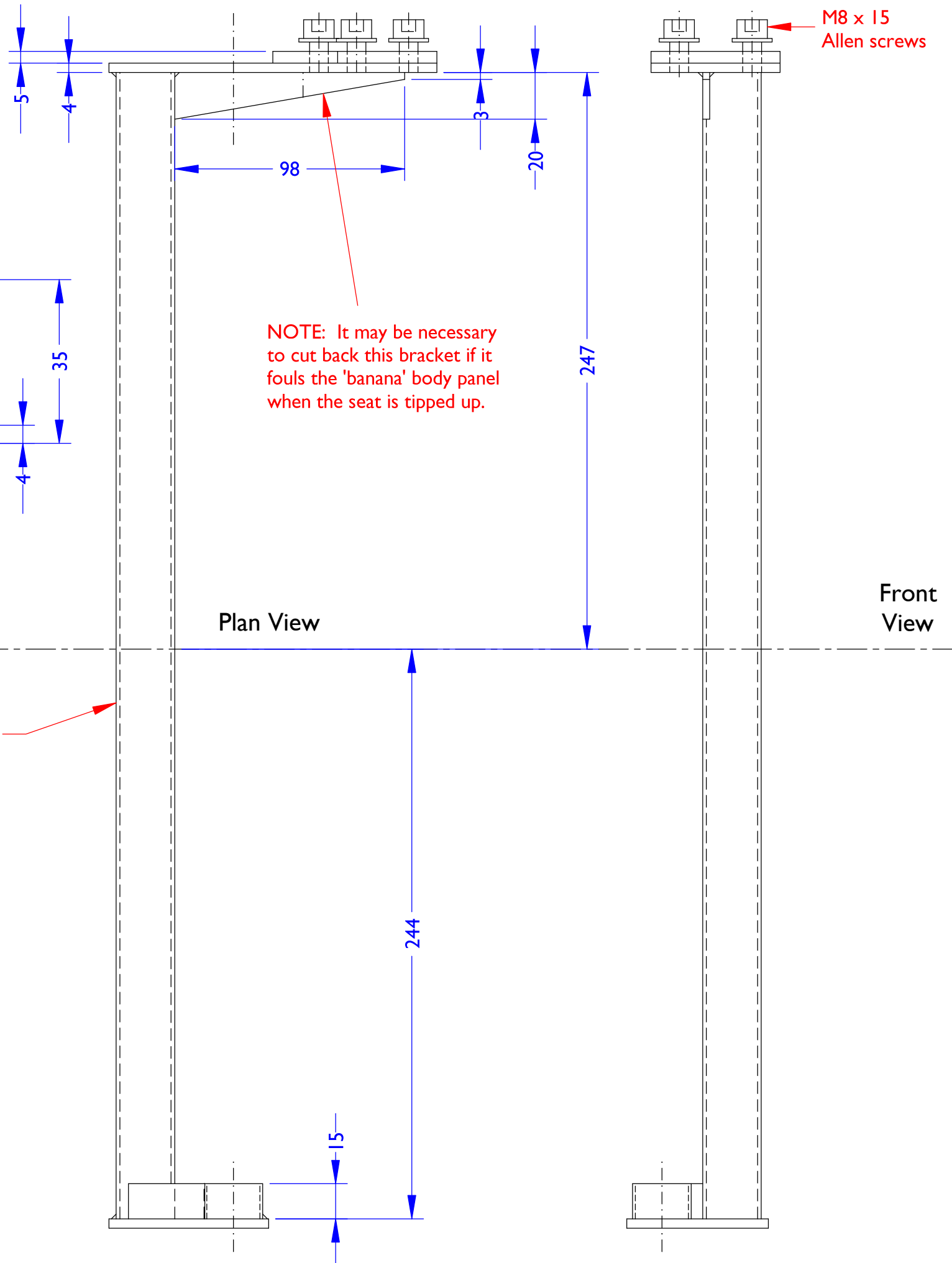

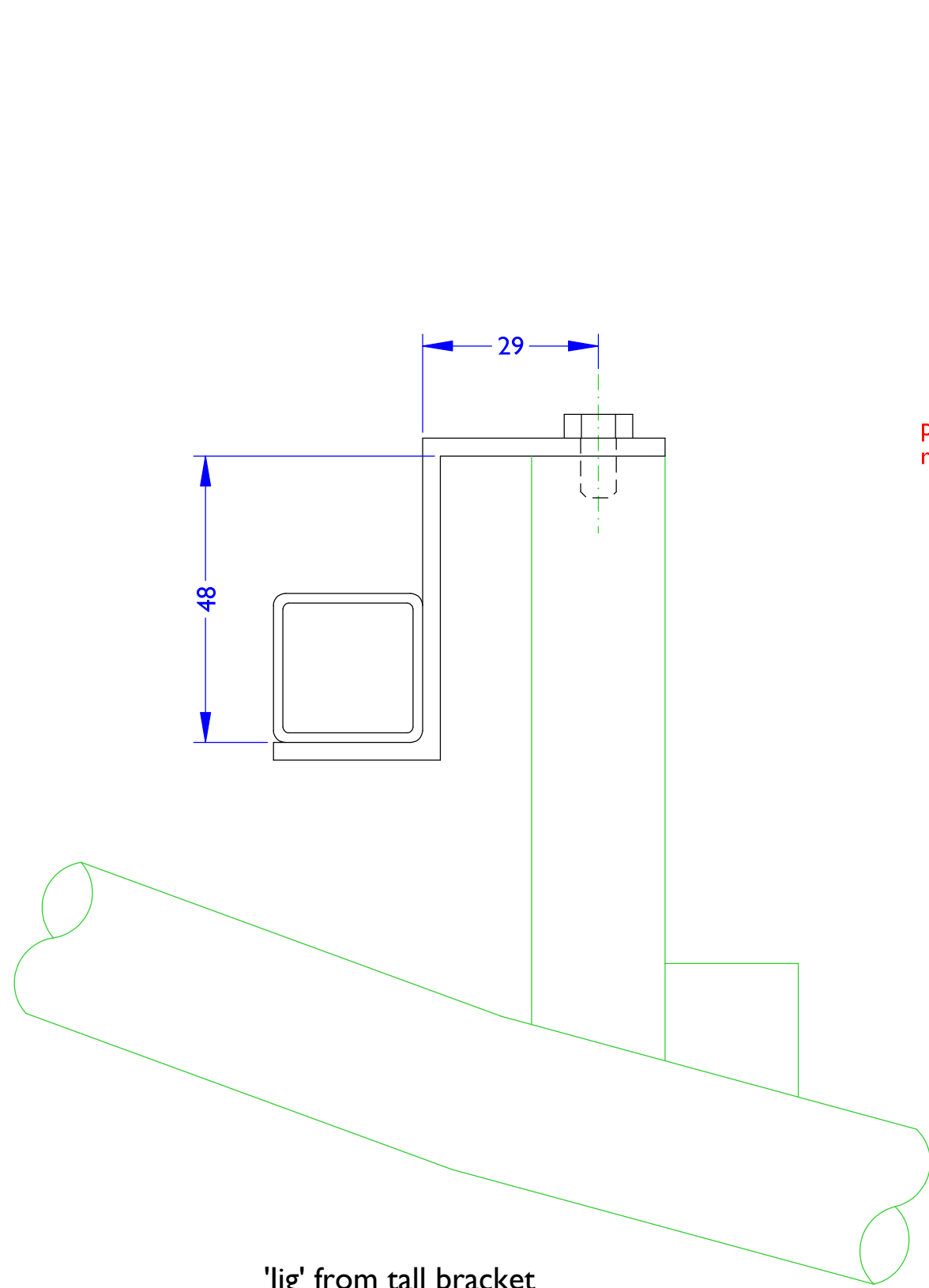

'Jig' from tall bracket  
used to position seat bar

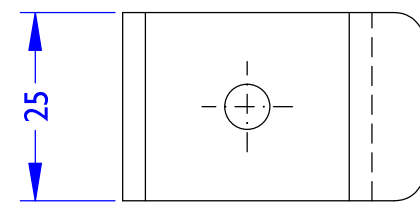

Round edges to  
prevent damage to  
rubber on seat bar

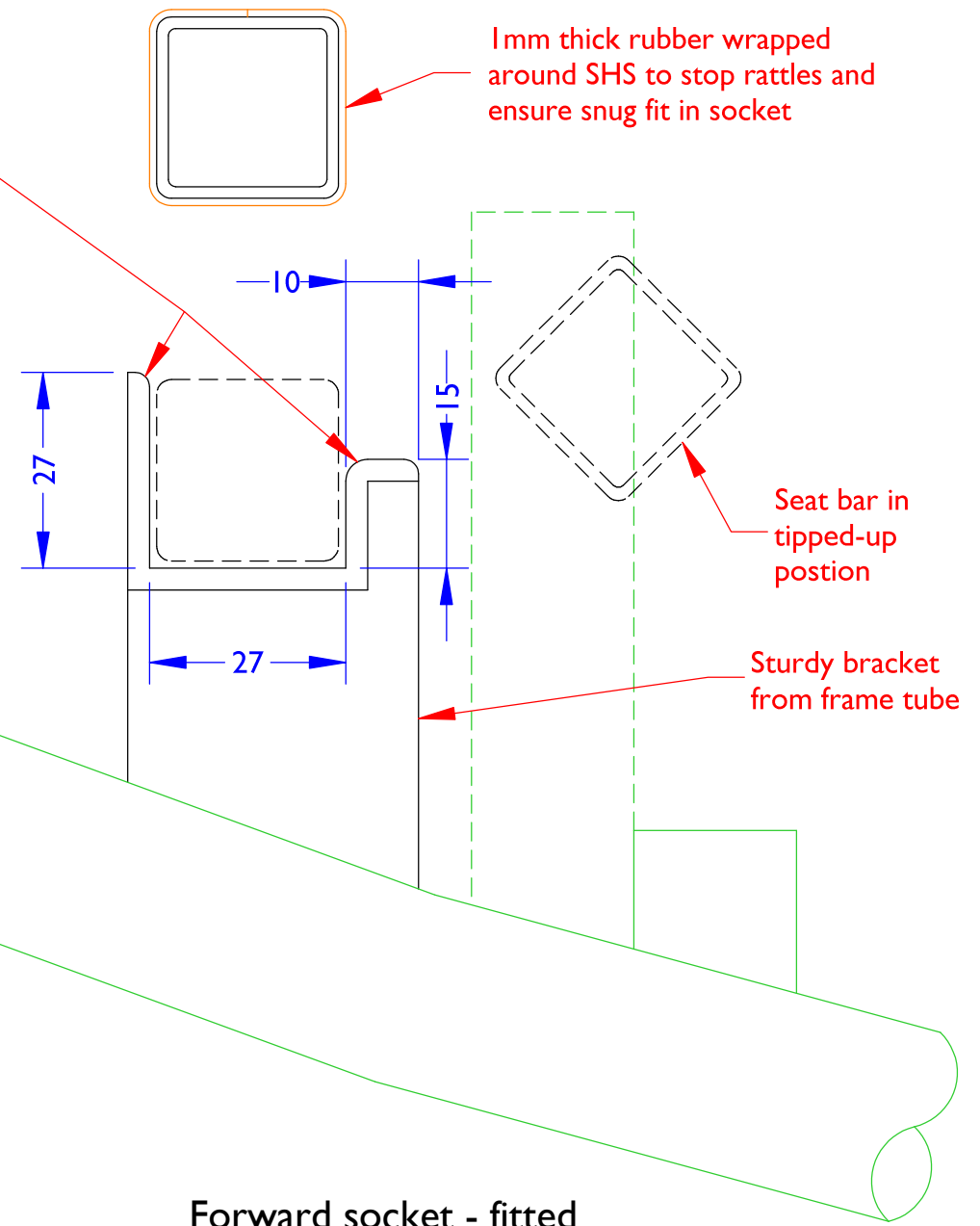

Forward socket - fitted  
to seat bar when in 'jig'

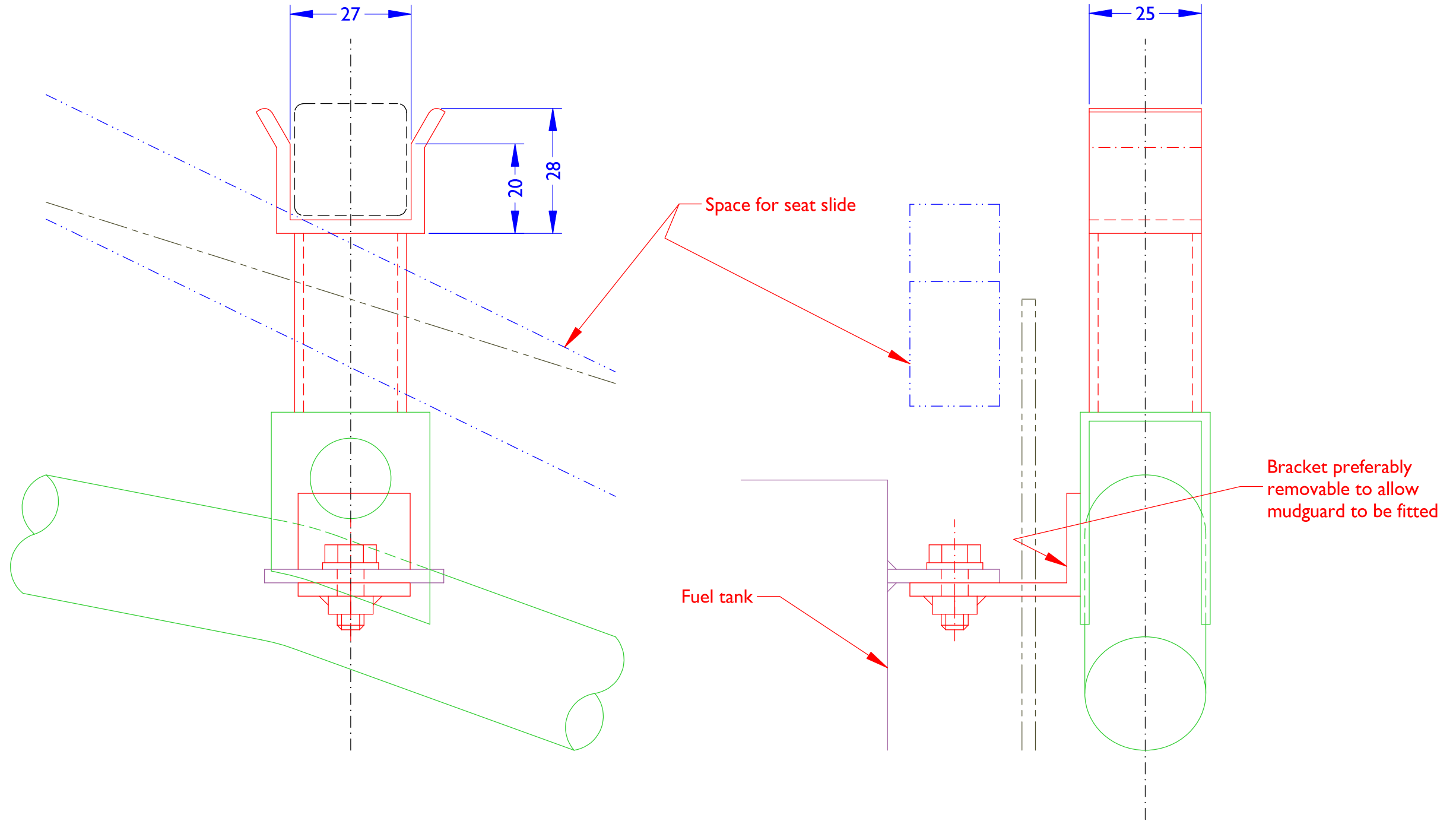

Side View

Cross Section

**COMFORTMAX**  
**Rear Seat Bar Socket**  
**& Fuel Tank Bracket**  
**1:1**

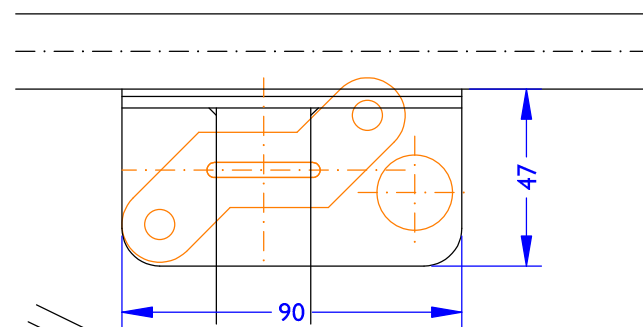
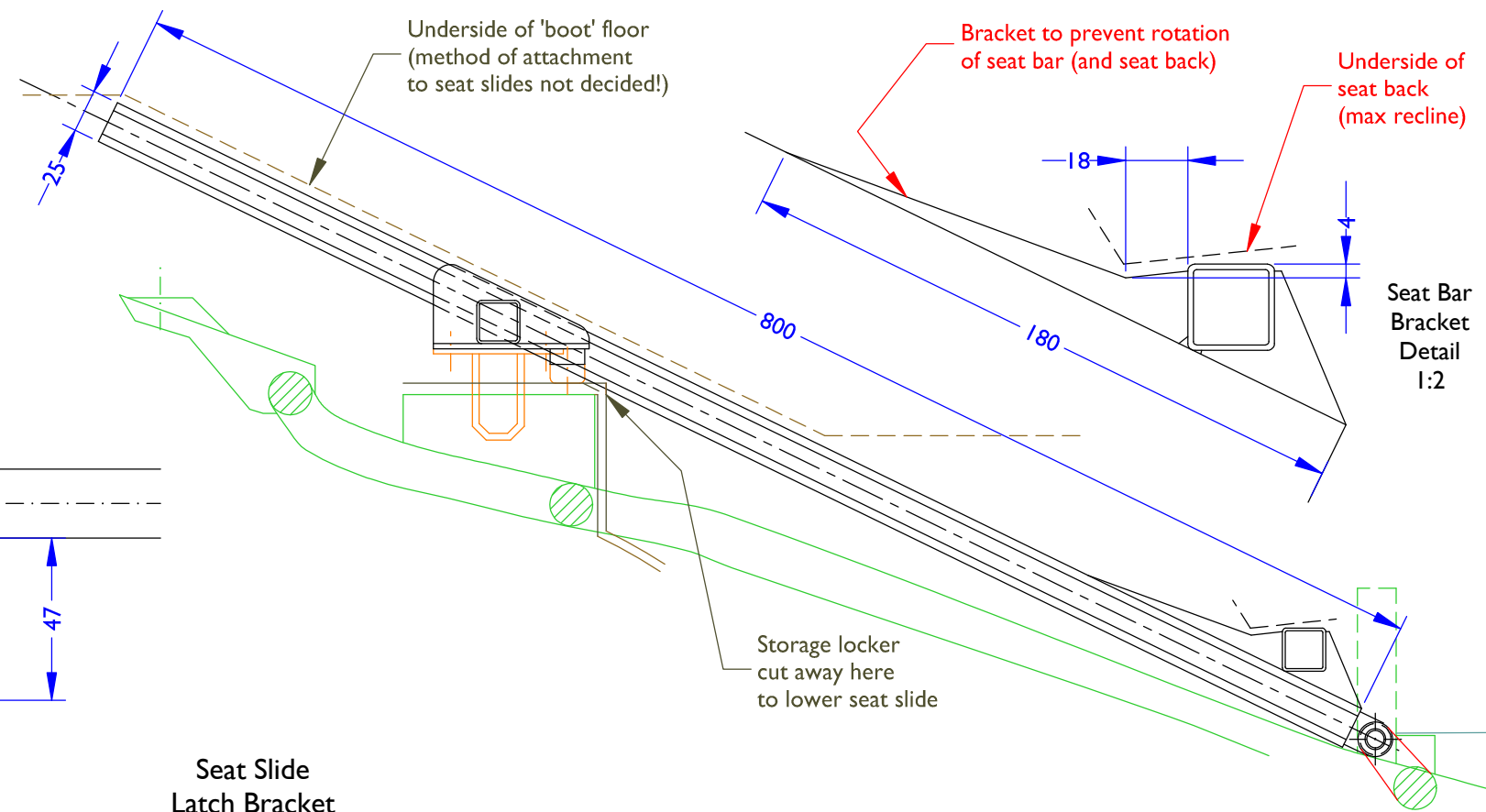
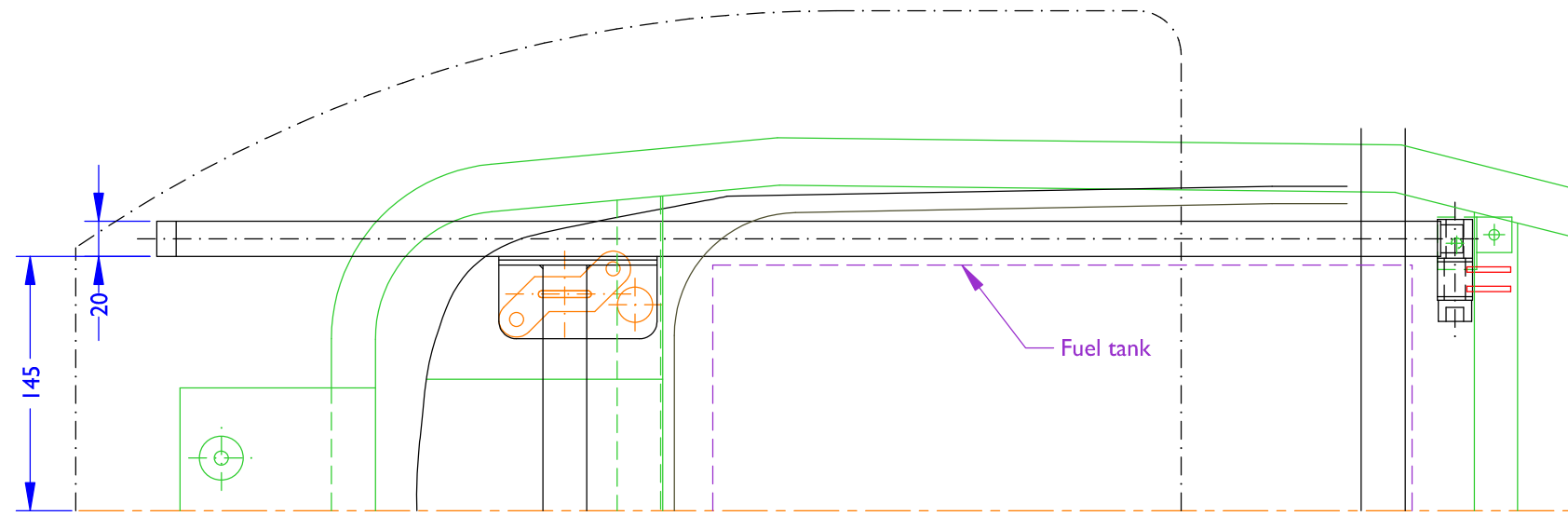

Seat Slide  
Latch Bracket  
Detail  
1:2

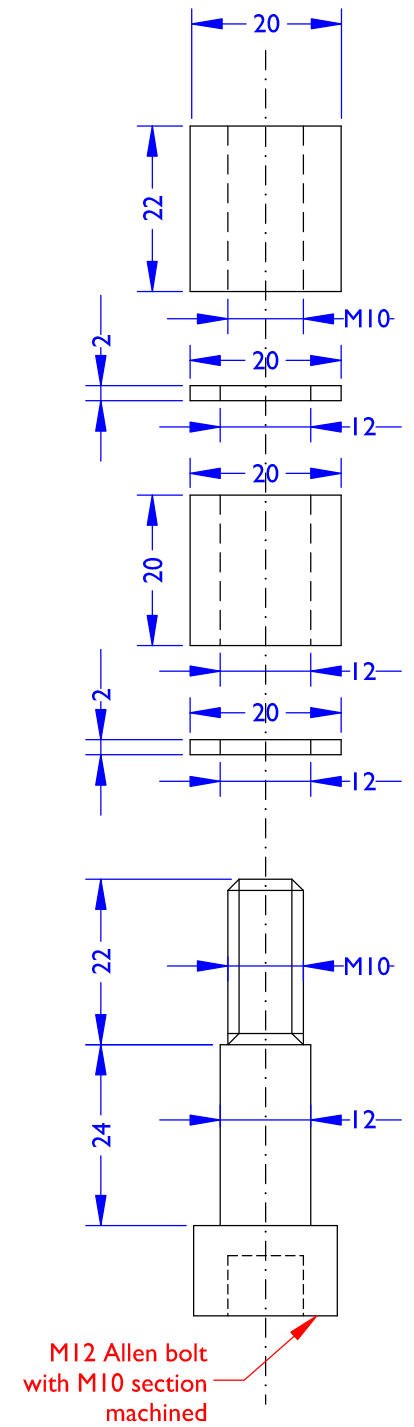
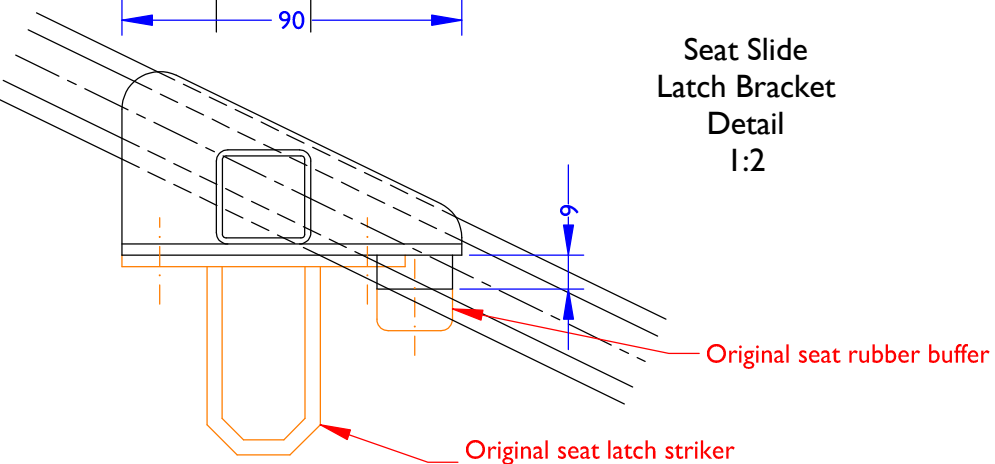

**COMFORTMAX**  
Seat Slide  
1:4

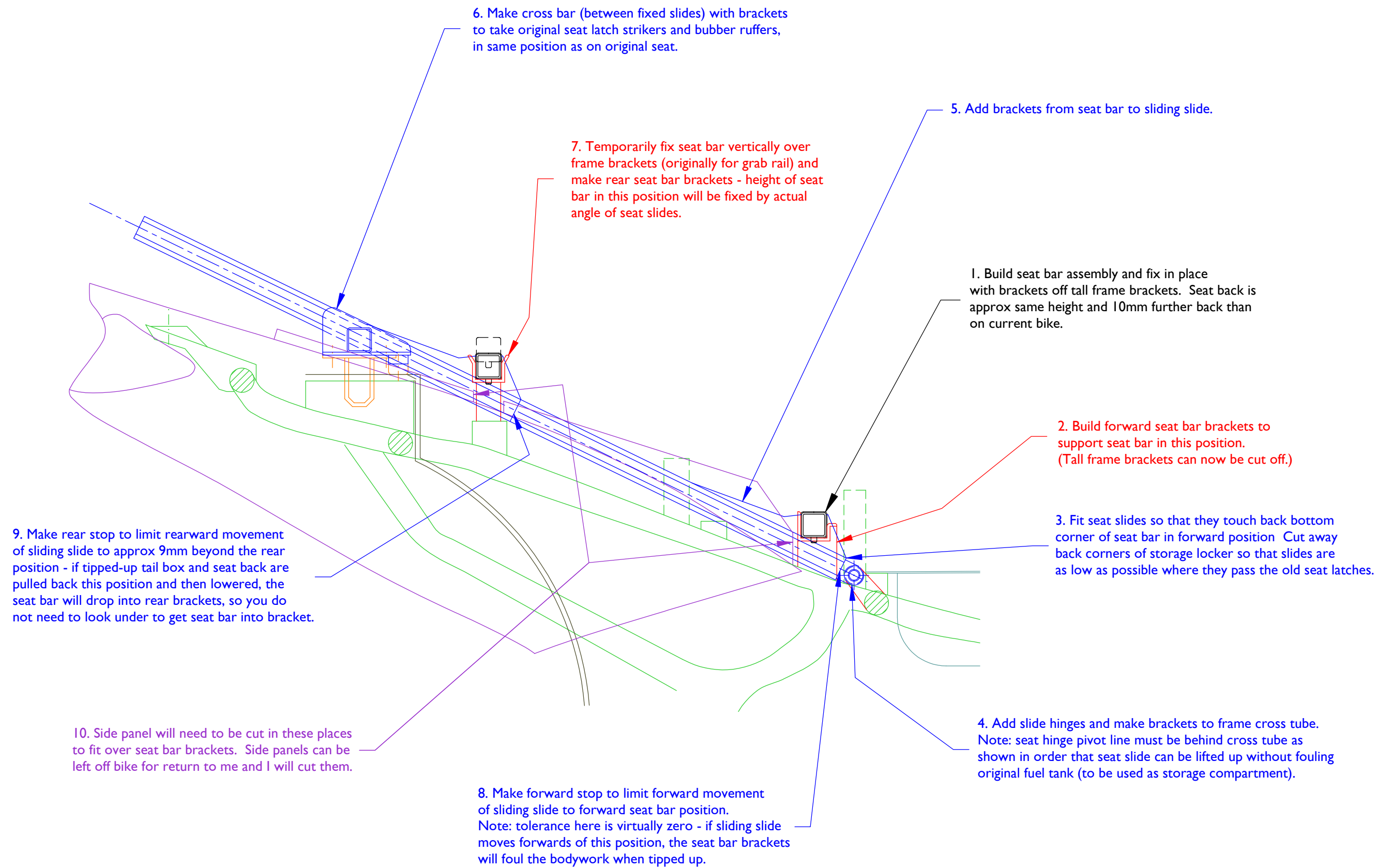

**COMFORTMAX**  
**Seat Slide Assembly Sequence**  
**1:4**